

HRV1.25 Q Plus

Highly energy efficient Heat Recovery Ventilation Unit



Primarily for use in dwellings with three wet rooms or fewer

The revolutionary ultra compact HRV1.25 Q Plus continuously running whole house ventilation unit with heat recovery is independently tested by the BRE and is EST Best Practice compliant. The HRV1.25 Q Plus has been specifically designed to give improved performance over older models without increasing the overall size of the unit.

The combination of ultra low power consumption and a highly efficient

heat exchanger is specifically designed to enhance SAP performance via Appendix Q, yet the unit remains small enough to be easily incorporated into apartments and smaller houses where space is at a premium. The HRV1.25 Q Plus has many features, including removable airtight filter covers for ease of use, as well as Summer Bypass and Humidity Sensor versions.



Features & Benefits

- Very compact unit can be fitted in airing cupboards, small service cupboards or loft spaces
- Lowest power consumption / specific fan power on Titon compact units
- Highly efficient heat exchanger; up to 91%
- Three versions available (the same dimensions): 'A' (includes a Summer Mode), 'MB' includes a Summer Bypass, 'HMB' includes Summer Bypass and Humidity Sensor
- MB and HMB versions compatible with auralite® status indicator
- Intelligent controller, quick and easy to commission
- Fully adjustable boost overrun timer 0-60 minutes; can be used with non-latching (momentary) switches to prevent unit from being accidentally left in boost mode
- Accepts 100mm or 125mm diameter ducting, no adaptors required
- Intelligent frost protection, stepped reduction of supply air rates prevents freezing
- Setback facility to reduce ventilation where local regulations allow
- Very lightweight for easy handling
- Demand Control Ventilation ready
- Volt free switching control
- Removable filter covers for easy access filter maintenance
- G3 filters as standard, G4 as an option
- Re-usable plastic filter frames
- Quick fix via mounting bracket
- Patented features

Description

Titon HRV1.25 *Q Plus* whole house central mechanical supply and extract unit with heat exchanger

Product Codes

TP406A

Filters: G3-XP40032/099 G4-XP46022/099

TP406MB (with Summer Bypass and auralite® ready)**

Filters: G3-XP40032/099 G4-XP46022/099

TP406HMB (with Summer Bypass, Humidity Sensor and auralite® ready)**

Filters: G3-XP40032/099 G4-XP46022/099

Standards

Conforms to requirements of UK statutory Building Regulations and Technical Standards for Ventilation and BRE 398.

SAP Appendix Q tested (www.sap-appendixq.org.uk).

Exceeds requirements of Building Regulations Approved Document L (England & Wales).

EU RoHS Directive compliant.

Conforms to requirements of EC council directives relating to Electromagnetic Compatibility and Electrical Safety: 2006/95/EC (LVD), 2004/108/EC (EMC) EN 60335-1:2002/A2:2006, EN 60335-2-80:2003/A1:2004. CE Marked. Other non-UK info available on request.

Specification

Dimensions: 600mm wide x 430mm high (excluding ports) x 285mm deep (295mm with mounting bracket)

Weight: 16kg

Finish: White Paint

Materials

Housing: Zintec sheet steel housing, powder coated white
Internals: Expanded polypropylene (EPP)
Heat exchanger: Polystyrene
Internal insulation: Closed cell foamed Nitrile rubber, class 'O' fire rating
Standard filters: Grade G3 synthetic filters, flame resistance to BS5588

Guarantee period: 3 years (UK only)

Electrical: 230V ~ 50/60Hz, 3A fuse
Installation: Install in accordance with Good Practice, such as the Domestic Ventilation Compliance Guide (England & Wales) and the Residential Ventilation Association recommendations

Maintenance: Service and filter clean/replacement subject to local environment - see Product Manual.

Details

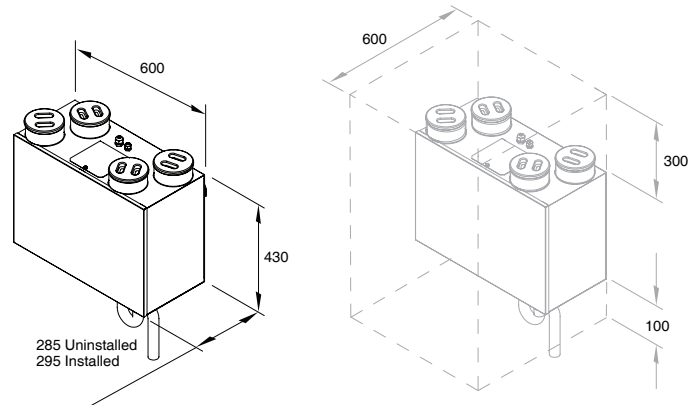

Performance

The figures and compliance levels below relate to current SAP requirements. Revised SAP guidance will have an effect on performance and up to date figures can be found on the relevant product page at www.titon.co.uk

Exhaust terminal configuration*	Fan speed setting	Specific fan power (W/l/s)	Heat exchange efficiency (%)	Energy Saving Trust Best Practice Performance Compliant
Kitchen + 1 additional wet room	100% variable	0.53	91	Yes
Kitchen + 2 additional wet room	100% variable	0.60	89	Yes
Kitchen + 3 additional wet room	100% variable	0.75	89	Yes
Kitchen + 4 additional wet room	100% variable	0.98	88	Yes

Figures taken from the BRE Test Results

*Number of wet rooms is based on SAP Q test criteria and does not correlate directly with regulatory performance requirements

Noise Performance - details on request

**The TP406MB and HMB versions may differ slightly due to the Summer Bypass option

Nominal fan performance

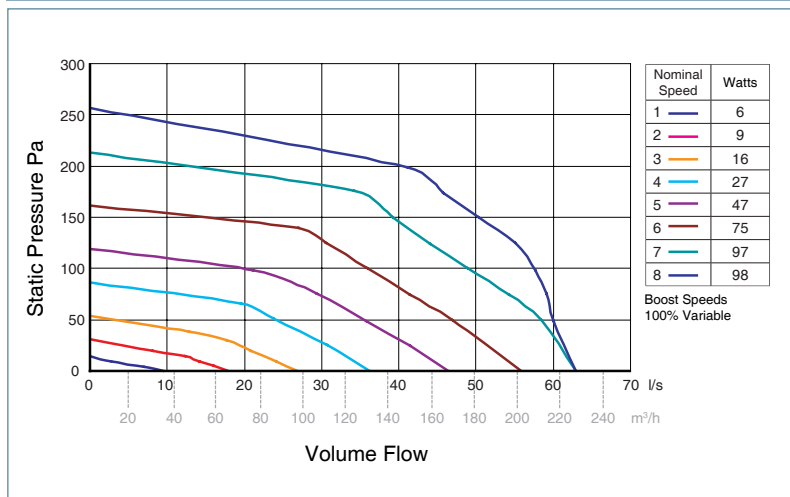

TP406MB and HMB performance graph available on request